

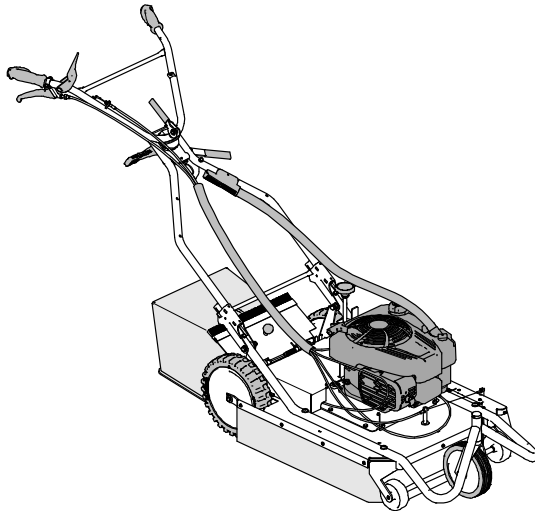

Operator's Manual



WeedHex

AS 50

From serial number: 032919010001

Issued: 31 January 2019, V12.0

en-Translation of the Original Operator's Manual

Notes on the operating manual

Dear customer,

Congratulations on your purchase. You have acquired a reliable quality product by "AS-Motor Germany".

This product has been manufactured according to modern manufacturing methods and comprehensive quality assurance measures. Only when you are satisfied with your device have we attained our goal.

These operating instructions contain important information to help you avoid hazards and to increase the reliability and the life span of the device.



Read the operating instructions before using the device. Share these operating instructions and the operating instructions of the engine with other users of the device.

Contact

If you have questions about your device, please contact your customer service.

For international AS partners, please see: www.as-motor.de.

Device data

Please fill in all data referring to your device. When ordering spare parts, provide your dealer with the serial and engine numbers.

Serial number (see manufacturer's certificate or type plate):

Engine number:

Date of purchase:

Address of dealer:

Intended use

The device is exclusively intended for cleaning paved areas and edges where moss and weeds are growing.

Only use attachments and cutting tools authorised by "AS-Motor Germany".

Any other use exceeding this purpose is inadmissible.

Observe the instructions chapter for Maintenance. Otherwise, operational safety is endangered.

The user of the device is responsible for accidents or damage that can happen to other persons or their property.

The device shall in particular **not** be used

- on public roads.
- as drive unit for work tools and any type of tool sets that are not authorised by "AS-Motor Germany".
- for sweeping and mowing unpaved areas.

Contents

Notes on the operating manual	2	Maintenance	18
Contact	2	Maintenance overview.....	19
Device data	2	Cleaning the device.....	21
Intended use	2	Basic inspection.....	21
Explanation of the symbols	4	Checking the engine brake.....	21
Symbols in the instructions.....	4	Checking the brushes.....	22
Warnings.....	4	Changing the brushes.....	22
Signs on the device.....	4	Checking the brush strip and the brush holder.....	23
Safety instructions	6	Maintaining the engine.....	23
Get informed!.....	6	Checking the engine oil level.....	23
User restrictions and hours of operation..	6	Checking the spark plugs.....	24
Safe handling of fuel.....	6	Maintaining the air filter.....	24
Check the device prior to use.....	7	Checking the drive.....	24
Danger area.....	7	Assembly	25
Use caution during operation.....	8	Scope of delivery.....	25
Prior to brushing.....	8	Unpacking.....	25
Use caution during brushing.....	9	Guide bar and handlebar.....	25
Caution at steep slopes.....	9	Dirt collecting bag.....	26
When work is completed.....	10	Storage	27
Use caution during maintenance and repair.....	10	Storing the device.....	27
Device description	11	Longer storage.....	27
Control elements	12	Restarting.....	27
Information on brushing	13	Spare parts	27
Prior to starting	13	Wear parts	27
Fuel.....	13	Disposal	27
Tanking up.....	13	Warranty	27
Checking the engine oil level.....	13	Troubleshooting	28
Starting	14	Technical data	30
Starting the device.....	14	Accessories	31
Adjusting the contact pressure of the brushes	14	Declaration of conformity	32
Adjusting pressure of brushes.....	15		
Driving	15		
Driving.....	15		
Turning.....	15		
Brushing at a kerb or wall	16		
Switching off and parking	16		
Transport	17		
Loading.....	17		
Unloading the device.....	17		

Explanation of the symbols

Symbols in the instructions

In these operating instructions, the following symbols are used to denote special dangers.



Warning.
These symbols denote special dangers.



Prohibition sign.
These symbols denote inadmissible procedures.



Directive sign.
These symbols denote required protective measures.

Warnings

In these operating instructions, warning instructions are marked with signal words. The signal words are used to indicate the following hazards and potential consequences.

Danger

Imminent danger

Indicates an imminently hazardous situation with a **high level of** risk that, if not avoided, **will** result in minor or moderate injury.

Warning

Hazardous situation

Indicates a possibly hazardous situation with a **medium level of** risk that, if not avoided, **could** result in minor or moderate injury.

Caution

Hazardous situation

Indicates a possibly hazardous situation with a **low level of** risk that, if not avoided, **could** result in minor or moderate injury.

Notice

Danger of property damage

Indicates a possible risk of damage of the device and its surroundings.

Signs on the device

The following signs are attached to the device to provide a reminder that during use of the device, you will have to be careful and attentive:



Working with the device requires extreme cautiousness. Read the operating instructions before you use the device.



Risk of injury!
Make sure that no one is within the danger zone of the device. Objects may be ejected. The danger zone extends for at least 15 metres.



The rapidly rotating tool can cause life-threatening injuries or significant damage! Pay special attention to keeping your hands and feet away from the tool when the device has been put into operation.

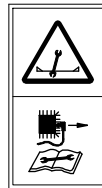

Prior to any repair and maintenance work, pull off the spark plug connector.



Noise is causing health problems. Use personal ear protection to avoid hearing damage.



Do not clean the device with water spray or high-pressure cleaner!

Type plate

The type plate on the device provides you with information on the device type and the technical data.

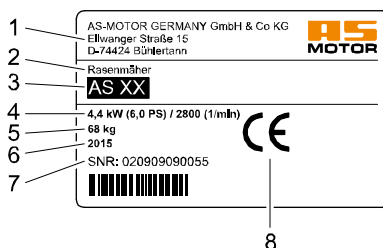

- 1 Name and address of the manufacturer
- 2 Device designation
- 3 Type designation
- 4 Rates power output in kW / engine speed
- 5 Weight
- 6 Year of manufacture
- 7 Serial number
- 8 CE marking

Safety instructions

Get informed!

For your safety, read these operating instructions carefully. Familiarize yourself with the control elements and the proper use of the device. Share these operating instructions with other users of the device.

Have skilled personnel who were trained by AS-Motor show you the safe handling of the device before you work with it for the first time.

Get familiar with the device in a wide, open and flat terrain first.

When working on or adjacent to public roads, observe the local regulations, if necessary.

User restrictions and hours of operation

Never allow children or persons who are not familiar with the operating instructions to use the device. Persons under 18 years of age may operate the device only under proper supervision. Local regulations determine the minimum age of the operator and the operating times.

Unsuitable for operation of the device are persons who

- are under the influence of alcohol, drugs or reaction retarding medicines.
- have physical and mental/emotional impairments.
- are tired or sick.



People fitted with pace makers are not allowed to touch any current carrying parts of the ignition system.

Safe handling of fuel

Fuel is toxic and highly flammable. There is a burn and explosion hazard!

Keep fuel away from ignition sources and do not smoke during handling.

Do not inhale fuel vapours, they are dangerous to your health.

Use gloves and avoid skin contact with the fuel.

Always refuel outdoors when the engine is cold and stopped completely. When doing so, always use a filler spout or a funnel.

Do not spill any fuel or do not let fuel enter canalisation or drain away.

When fuel has overflowed, do not start the device until the fuel vapours have evaporated (wipe dry). Move the device away from the spilled fuel.

Always close the tank cap tightly and do not open it while the engine is running or the device is still hot.

Empty the fuel only when outdoors. Use the approved container for this or run the fuel tank empty.

Store the fuel away from children and keep it in a suitable container in a dark, cool and dry place.

Never store the device when there is fuel in the tank inside a building where fuel vapours might come into contact with open fire or sparks.

Immediately replace the fuel tank or tank cap if they are damaged (authorised service centre).

First aid

When swallowing fuel or inhaling fuel vapours, do not force vomiting and immediately consult a doctor.

In case of skin contact, immediately wash with water and soap. Change your soiled clothing as soon as you can.

Measures in case of a fire

In case of a fire, use foam, dry powder extinguisher, or carbon dioxide (CO₂). Never douse with water!

Check the device prior to use

Prior to use, check the brushes, protection skirt, covers, drive and fastening parts, cables and cable connections for proper working condition and firm seating by visual inspection.

Never use the device with defective or missing covers, brush strip, side and rear flap, protection skirt, or dirt collecting bag.

Do not remove, change or override any safety devices or control elements.

Observe the maintenance instructions (see chapter Maintenance).

Have an authorised service centre check your device if the blade does not stop within 3 seconds.

Danger area

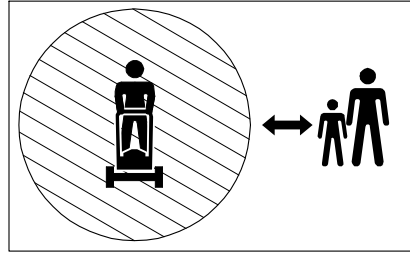

The danger zone extends for at least 15 metres.

Within the danger area of the device, there is a risk of injury.

The rotating brushes can cause injuries and objects can be thrown out. The area in front of and to the right of the device is especially dangerous.

On slopes, the device can topple over and slide towards persons or run them over.

Make sure

- that nobody else besides the user is on the work area.
- that people are never positioned in the direction of travel in front of the device.
- that nobody is positioned on the slope below the device.
- that you have a complete overview of the danger area at all times.
- that you keep your hands and feet away from the rotating parts.

Use caution during operation

Danger of injury during motor start

Do not start the engine

- if fuel was spilled.
- in closed or poorly ventilated rooms (danger of poisoning!).
- if there are other persons nearby.

Only start the device when your feet are at a safe distance to the brushes.

When the engine is started, the device must not be tilted.

Risk of injury when the motor is running

Switch off the engine and wait until the brushes stop

- before you tilt or transport the device.
- before you step away from the device, even for just a short time.
- if you drive over an area to be worked on.
- before you refuel.

Switch off the engine, wait for the brushes to stop and remove the spark plug connector

- before you clean or check the device or before you carry out work on the device.
- before you unblock or unclog the discharge area.

Risk of burns

Do not touch the engine or the silencer. These parts become very hot during operation and you can get burned. If a jumpy movement occurs, the risk of additional injuries can result.

Prior to brushing

Personal protective measures



During brushing, always wear safety shoes with good grip, long trousers, and gloves. Do not brush with open sandals or while shoeless.



Noise is causing health problems. Use personal ear protection to avoid hearing damage. Wear safety glasses during work.



In case of high dust development, wear a dust mask.



Wear safety gloves to protect yourself against injuries and vibrations.

Ask your specialised dealer about suitable protective equipment.

Preparing the work area

Check the area to be brushed carefully prior to starting work. Remove all rocks, sticks, wires, or other objects that can be propelled away from the device.

Use caution during brushing

Risk of injury

Risk of injury caused by ejected objects. Never brush when persons, children, pets or objects are in the danger area.

Keep your hands and feet away from the rotating parts. Keep a distance to the ejection area while working with the device.

Make sure that help can be provided in case of an emergency.

Only work during daylight or with adequate artificial lighting. Never work in the event of uncertain weather conditions and risk of lightning.

Be extremely cautious when turning the device round or pulling it toward you and when moving in reverse.

Always walk slowly!

Never lift or carry the device when the engine is running.

Pay attention to traffic when working close to roads.

Vibrations

When the device is used over a longer period of time, vibrations can cause disturbances in the blood supply of the hands. A generally accepted usage time cannot be determined.

- Use gloves.
- Take breaks on time.

Have an authorised service centre check the device

- if the brushes or brush strips hit an object.
- if the device starts to vibrate unusually severely.

Fire hazard

The brushes produce sparks as they stroke over the stones.

There is a burn and explosion hazard.

- Never brush in explosive areas.

Brushing areas with fire hazard

- Slightly moisten flammable material before you brush over it.
- Carry a sufficient amount of suitable extinguishing media.
- If the device leans too much to the side, fuel can leak from the carburetor or the tank. This presents a fire hazard!
- Observe the moved area even after brushing to make sure that no fire breaks out.

To prevent a fire hazard, always keep the following components free of dirt, grass, hay, leaking oil, grease, etc.:

- Engine
- silencer (manifold, protection, spaces)
- area around the fuel tank

Caution at steep slopes



Risk of injury during working on slopes due to tipping over or sliding.

- Brush on steep terrain only when safe operation can be guaranteed.
- Do not brush excessively steep areas.
- Always brush crossways to the slope, never upwards or downwards.
- Always make sure that you step safely, use non-slip safety shoes.
- Be extremely cautious when changing the direction.
- Brush only when the ground is dry and has a good grip.

When facing downhill, the device can roll away. Park the device on level ground only and secure it against rolling away.

Devices fitted with a four stroke engines may only be operated on less than 20° slopes. Otherwise, the four stroke engine can be damaged due to insufficient oil lubrication.

If the device tilts or slips

- If you attempt to stop a device that is tilting or slipping, severe injuries can result. If tilting or sliding cannot be stopped in the beginning without endangering anyone, do not continue to try to stop the device.
- Remove leaking fluids (oil, fuel, battery acid) from the device and the floor. Deposit of contaminated soil environment friendly according to the local regulation.
- Undetectable damage may have occurred to the device. In case of malfunctions, there is a risk of injury. Have an authorised service centre check the device.

When work is completed

After each brushing, close the fuel valve.

Prior to leaving the device, wait until the brushes come to a standstill and pull off the spark plug connector.

After switching it off, let the device cool down for at least 20 minutes before you store it in a dry, closed, sufficiently ventilated room.

Never store the device when there is fuel in the tank inside a building where fuel vapours might come into contact with open fire or sparks.

Use caution during maintenance and repair

Only carry out maintenance work as described in these operating instructions. Have an authorised service centre perform all other work.

Only use the brushes and spare parts authorised by “AS-Motor Germany”. Unauthorized brushes and spare parts can cause severe injuries.

Prior to all maintenance work, wait until the brushes come to a standstill and pull off the spark plug connector.

We would like to explicitly point out that, according to the product liability law, we cannot be made responsible for damages caused by our devices if

- worn or damaged parts were not repaired on time.
- if they were caused by improper repair.
- if, in case of a part replacement, other parts than our original components or components approved by us have been used.
- repair has not been carried out by an authorised service centre.

The same applies to spare parts and accessories.

Device description

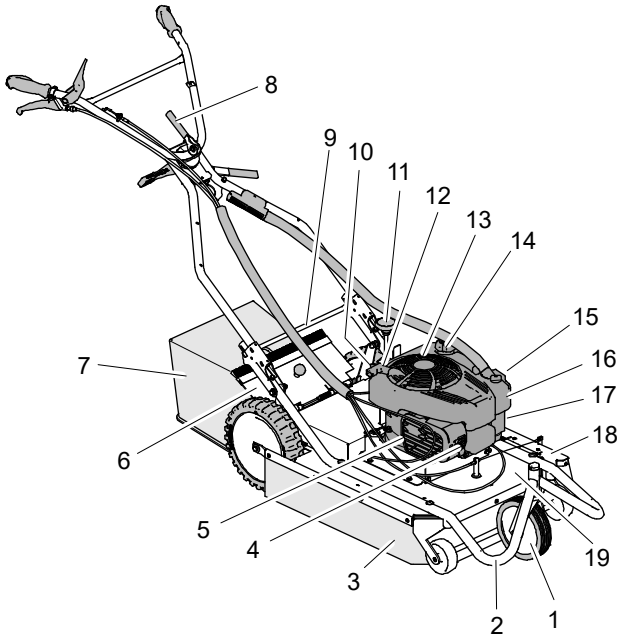

- | | |
|---|--|
| 1 Steerable front wheel | 11 Adjustment of contact pressure of brushes |
| 2 Protection bow | 12 Starter grip |
| 3 Protection skirt | 13 Ventilation grid |
| 4 Spark plug connector | 14 Tank filler spout |
| 5 Silencer | 15 Fuel valve |
| 6 Rear flap | 16 Air filter |
| 7 Collection bag | 17 Type plate |
| 8 Lever for lateral adjustment of handlebar | 18 Side flap |
| 9 Clamping lever to fasten bar | 19 Cover |
| 10 Oil filler neck | |

Control elements

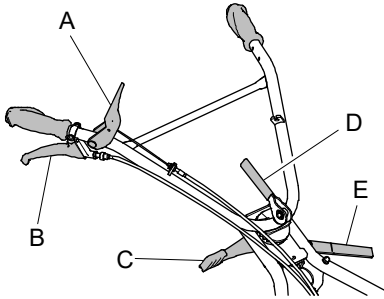

Engine brake bar (A)

The engine brake bar is a protective device. When you release the bar, the engine is shut off immediately, the brushes come to a standstill within 3 seconds.

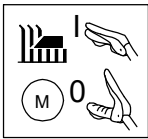

Brushes/engine on (I):
Press the bar towards the handlebar and continue to hold.

Brushes/engine off (0):
Release the bar

Drive lever (B)

With the drive lever, you switch the drive on and off.

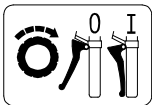

Drive off (0):
Release the lever.

Drive on (I):
Press the lever towards the handlebar and continue to hold.

Vario lever (C)

With the vario lever, you can continuously adjust the speed of the device while the engine is running.

MIN: slow

MAX: fast

Lever for lateral adjustment of handlebar (D)

1. Release the eccentric tension lever.
2. Attention: Do not crush the Bowden cables when pivoting the handlebar.
Swivel the handlebar to the side to the desired position.
3. Clamp the handlebar with the eccentric tension lever.

Lever side flap (E)

You require the side flap for brushing near a pavement or wall. Pull the lever for the side flap towards you to open the side flap.

Fuel valve

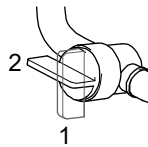

1: Closed

2: Open

Information on brushing

Prior to brushing, check the device for completeness, proper function, and cleanliness. A dirty ventilation grid causes overheating of the engine which can result in engine damage. A dirty protective grid at the silencer poses a fire hazard.

During brushing, wires can be left behind. Remove these wires after the work is completed. Brush only areas where remaining wires do not pose a hazard.

Performance depends mainly on the type and degree of contamination.

The ideal engine speed is fixed.

If the engine speed drops significantly during removal of thick growth, we recommend:

- Reduce the driving speed.
- Pull back the device and brush over the area for a second time.
- Reduce the brush pressure and brush over the area for a second time.

If the engine speed drops significantly during working on uneven surfaces, we recommend:

- Reduce the brush pressure.
- Brush the area, if possible, for the second time, in a different direction.

Do not move over edges or steps when the engine is running.

To prevent excessive dust formation, operate the device preferably when weather conditions are humid. If this is not possible, wear a dust mask or sprinkle some water on the area.

To make sure that weeds and dirt are ejected without clogging, we recommend to brush only while moving forward.

Prior to starting

Fuel

As fuel, use unleaded petrol (see operating instructions of the engine manufacturer).

You can use E10 petrol. Do not store E10 petrol longer than 30 days.

Tanking up

Warning

Fuel is ignited by hot engine parts.

- ▶ Prior to filling up, switch off the engine and wait for at least 20 minutes until the engine has cooled down. Observe the safety instructions regarding the fuel!

Filling up with fuel

1. For filling, use a canister with filler spout or a funnel.
2. Open the canister carefully so that existing excess pressure is slowly reduced.
3. Open the tank cap carefully so that existing excess pressure is slowly reduced and no fuel sprays out.
4. Fill the fuel tank.
5. Tightly close the tank cap again.

Checking the engine oil level

Beware! Prior to each use, check the engine oil level (see operating manual of the engine manufacturer).



To ensure an adequate oil supply for the 4-cycle engine and to avoid engine damage, the device may only be used up to a slope inclination of 20 degrees.

Starting

Warning

During startup, there is a risk of injury caused by the rotating brushes.

- ▶ Make sure that no one is within the danger zone of the brushes. Do not tip the device over to one side during startup.

Warning

Danger of poisoning due to poisonous exhaust gases.

- ▶ Do not operate the engine in closed or insufficiently ventilated rooms.
- ▶ Please observe the safety instruction regarding the poisoning risk.

Warning

If after startup the carburetor does not close properly, fuel will overflow and a fire hazard occurs.

- ▶ Close the fuel valve and contact an authorised service centre.

Notice

Any imbalance can result in equipment damage within a very short time.

- ▶ In case of strong vibrations or noise development, switch off the engine immediately.

Starting the device

1. Place the device onto a flat surface, not in high grass.
2. Open the fuel valve.
3. Plug on the spark plug connector.
4. Actuate and continue to hold the engine brake bar.
5. Pull the starter point slowly out until you feel resistance then pull out quickly – engine starts to run.
6. Let the starter rope retract slowly.

Adjusting the contact pressure of the brushes

Notice

During adjustment of the brushes, damage to the ground can occur.

- ▶ Find a sturdy area for these adjustment operation.

The brush pressure can only be assessed while the engine is running.

Set the brushes only so low that they barely touch the ground.

The cleaning performance increases when the brush pressure increases, especially for hollows and tough growth.

Danger! If brush pressure is too high:

- The surface of the area to be worked on can be damaged.
- The brushes wear excessively.
- Parts of the area to be worked on can become loose and can be ejected or damage the device.
- Brush wires can break and be ejected or remain on the area to be worked on.

You know that the brush pressure is too high when

- strong formation of sparks occurs
- engine speed drops considerably
- the engine cuts off repeatedly

The time until the removed weed grows back is hardly affected by the cutting height; the brush wear, however, is significantly affected.

Adjusting pressure of brushes

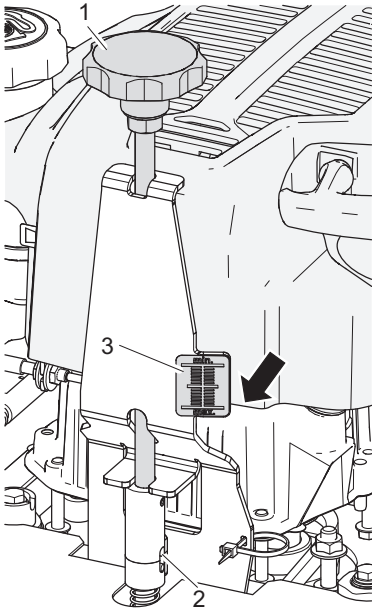

1. Place the device in a place that is not sensitive.
2. Start the device.
3. Press the central adjusting lever on the star grip (1) downwards into the drive slot (2).
4. Turn the star grip to adjust the height of the brushes and thus the contact pressure. The entire engine with the brushes is moved up or down. On the scale (3) the currently set height and the adjusting area is displayed.
5. Test the setting on a test area.

Driving

Warning

Risk of injury caused by tripping or sliding while pushing the mower, moving it backwards and turning it round.

- ▶ Make sure that the area is clear of objects and watch for safe footing.

Driving

Immediately switch off the brushes in case of a dangerous situation by releasing the engine brake lever.

Drive on:

1. Press the drive lever towards the handlebar – device is running.

Drive off:

1. Release the drive lever.

Adjusting speed:

The driving speed can be continuously adjusted with the vario lever.

Adjust the driving speed only when the engine is running.

Turning

Turning round on an even surface:

1. Switch off the drive.
2. Turn the device to the desired side.
3. Switch the drive back on.

Turning round on a sloping area:

1. Keep the drive switched on.
2. Turn the device upslope.
3. Hold back the handlebar and the inner wheel.

The drive prevents sliding and supports the turn manoeuvre.

Brushing at a kerb or wall

Warning

When you open the side flap, objects can be ejected.

- ▶ Make sure that no persons, pets, or property are within the danger zone.

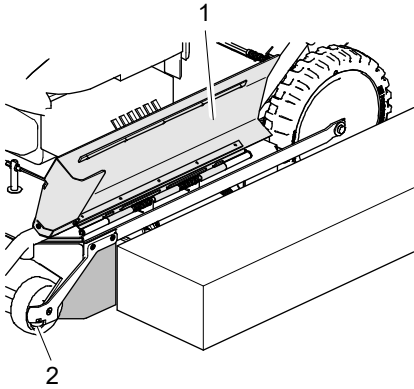

1. Move up to the area to be worked on as closely as possible.
2. Make sure that no persons, pets, or property are within the danger zone.
3. Lift up the side flap (1) using the side flap lever.
4. With the left side of the device, move up closely to the kerb or wall.
5. Release the side flap lever to close the side flap and to avoid the danger of objects being ejected.
6. The grinding protection (2) serves as guide along the kerb or wall.

Switching off and parking

Warning

On a slope, the device can roll away.

- ▶ Put the device on even ground only or secure it against rolling away.

1. Release the drive lever.
2. Release the engine brake bar.
3. Wait for the engine to stop completely before you step away from the device.
4. Close the fuel valve.
5. Pull off the plug connector.

Transport

Warning

Risk of injury due to the heavy weight of the device. The device can fall over and fall down and cause severe injuries.

► Observe the following notices.

Transport the device by truck or trailer designed for a payload of at least the empty weight of the device.

Switch off the engine and wait until the brushes stop before you lift the device. The device may only be lifted by two people.

Prior to each transport, let the device cool down for at least 20 minutes.

Close the fuel valve.

For transport, fold down the lever and the handlebar again.

Loading

Use suitable ramps for loading that

- can carry the empty weight of the device + 200 kg.
- are wider than the device.
- have a slip-free surface.

Notice

Risk of damage due to incorrect fastening of straps.

- Fasten the straps only at the points shown in the figure.
- Do not overtighten the straps.

1. Put the device in front of the ramps and make sure that the ramps
 - are as wide as the wheel gauge of the device.
 - are tightly secured to the platform.
 - are not steeper than 15°.
2. Carefully drive the device via the ramps onto the platform.
3. Observe the instructions in chapter Switching on and stopping.

4. Secure the device against rolling, sliding and tilting. Use straps that support the weight of the device.

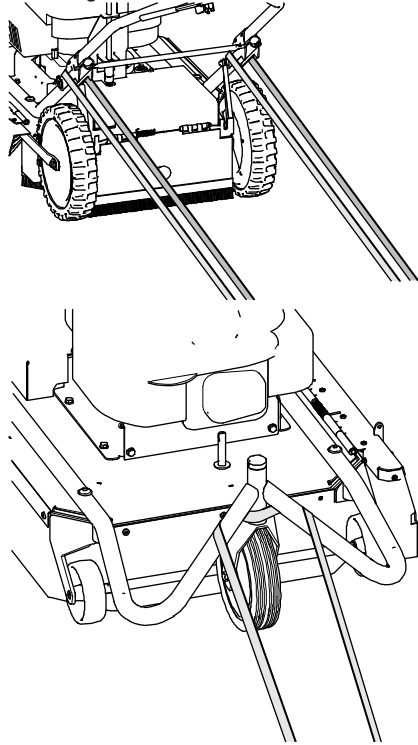

5. Secure the device with belts to the frame elements that can hold the weight

Unloading the device

1. Undo the transport fastenings.
2. Drive the device carefully down the ramps of the platform.

Maintenance

Warning

Risk of injury due to unexpected movement. When inspections are carried out, the device can move unexpectedly.

- ▶ Make sure that no persons or objects are in the danger area of the blade.
- ▶ Make sure that no further hazards result from an unexpected movement.

Warning

Risk of injury during maintenance and cleaning work when the engine is running.

- ▶ Perform maintenance tasks only then with a running engine if this is required in the Maintenance table.

Warning

Danger of poisoning due to poisonous exhaust gases.

- ▶ Do not operate the engine in closed or insufficiently ventilated rooms.
- ▶ Please observe the safety instruction regarding the poisoning risk.

Prior to all maintenance and cleaning work when the engine is not running:

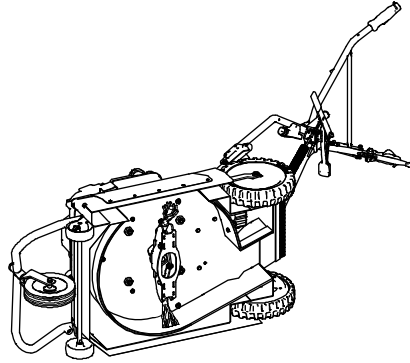

Notice

Engine oil can enter the air filter and damage it.

- ▶ Do not tilt the device towards the air filter side.

1. Let the device cool down for at least 20 minutes.
2. Pull off the plug connector.
3. Close the fuel valve.
4. Release the handlebar by pulling it towards the tie rod and flip the handlebar in a vertical position (do not damage the Bowden cables).
5. Tilt the device to the right as shown in the figure.

Improper maintenance can make the device unsafe for operation and result in accidents. Regular maintenance keeps your device ready for use.

Service the device according to the following maintenance instructions.

Contact an authorised service centre if problems during maintenance occur or if you determine deficiencies during one of the following inspections.

Maintenance overview

Component	Action	Maintenance interval	
		A	B
Device	Check for safe working condition (basic inspection).	■	▲
	Clean.	■	
	Customer service.		▲
Fuel	Check fuel level.	■	
	Is the tank cap closed?	■	
Tank, fuel valve, and fuel line	Check parts for leaks and check for good condition.	■	▲
Carburetor	Does the carburetor close again after starting?	■	▲
Ventilation grid	Clean.	■	▲
Engine cooling	Clean.		▲
Spark plug	Check/replace.		▲
Air filter	Maintain.	■	■▲
Brushes and fastening components	Check for wear and damage. See chapter Checking the brushes.	■	▲
Brushes	Change.	■	▲
Motor brake	Do the brushes stop in 3 seconds?	□	▲
Release the drive lever	Does the device stop when the lever is in zero position?	□	▲
Drive	Check.	■	▲
V-belt	Are the belts tensioned correctly, without fissures, and in good condition?		▲
Bowden cables	Check for proper function and ease of movement.	■	▲
Chassis and impact protection	Check for rust and fissures and check the welding seams.	■	▲
	Are all protective devices and covers in place, fastened correctly and properly functioning?	■	▲
Label	Condition of the labels.	■	▲
Engine	For reliable information, see the operating manual of the engine manufacturer.	■	▲
	Check oil level (see operator's manual of the engine manufacturer).	■	▲
	Oil change.		▲

Flammable material	Remove easily flammable debris from the engine and the device.	■	▲
Tyres	Check tyres and, if necessary, the tyre pressure.	■	▲

- A Before and after each use.
- B Annually or every 50 h.
- By the user when the engine is not running.
- By the user when the engine is running.
- ▲ By the authorised service centre.

Cleaning the device

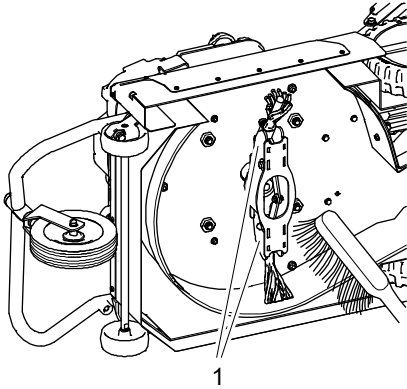

Stubborn residual dirt are harmful to the ejection and affect the brushing result. To ensure sufficient engine cooling, also keep the engine cover, ventilation grid, and the engine clean.

Keep the brush holders (1) especially clean. You must be able to swivel them easily otherwise there is a risk of unbalance.

Fire hazard! Pay special attention so that components at the silencer are clean.

For cleaning use a hand brush. Remove stubborn soiling with a wooden or plastic spatula. Clean the outer housing parts with a cloth.

Do not rinse off the device with a water jet or high pressure cleaner! Do not use aggressive cleaning agents.

Cleaning the dirt collecting bag

After brushing, clean the dirt collecting bag thoroughly with water. The fabric is to stay air permeable. Residue and dirt clog the fabric and thus worsens the collecting performance.

Basic inspection

To make sure that the device can be operated safely, check all nuts, bolts, screws, connections of fuel lines, air filters etc. regularly for proper condition and firm seating. Check the ignition wire and the spark plug connector for damage.

Immediately replace any damaged or used parts, especially covers, brush strip, side and rear cover, protection skirt, dirt collecting bag, silencer, or fuel tank (authorised service centre).

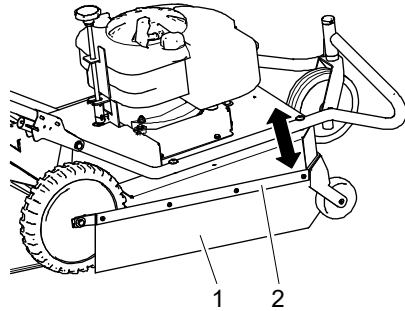

Check that the protection skirt frame (2) can be moved easily. When you tilt the device backwards, the protection skirt (1) must continue to touch the ground.

Check all parts that contain fluids for leaks and proper condition. These can be: Fuel tank, fuel valve, fuel lines, carburetor, engine, gears, battery, hydraulic system.

In case of leaks, contact an authorised service centre.

Checking the engine brake

Check the engine brake for proper function by switching off the engine. The brushes must stand still within less than 3 seconds. Contact an authorised service centre if this is not the case.

Checking the brushes

Warning

Improper maintenance, wear or damage to the brushes and fastening elements can lead to wires, brushes or fastening elements loosening and being hurled away. There is a considerable risk of injury.

- ▶ Check the brushes and all fastening elements according to the following instructions.

Notice

Unbalance of the brush system leads to destruction of the engine bearing and device.

- ▶ Never operate the device in case of unbalance of the brush system.

Check the brushes and fastening elements regularly prior to use and with noticeable changes for wear, damage and firm seating.

Strong noises or vibrations indicate an imbalance in the brush system. An imbalance can be caused by one-sided wear of the brushes or improperly used brushes

A change of the brushes is necessary

- If the wire bristles no longer touch and clean the ground despite the strongest contact pressure.
- If an imbalance exists.
- If the brushes are worn out unevenly.

Changing the brushes



Use solid gloves when you check or change the brushes.

Notice

Unbalance of the brush system leads to destruction of the engine bearing and device.

- ▶ Observe the following notices.

- Change the brushes only in pairs.
- For replacement of the brushes use only new brushes, never used ones.
- Always push the brushes all the way into the brush holder.
- If the brushes cannot be inserted easily into the brush holder, contact an authorised service centre.

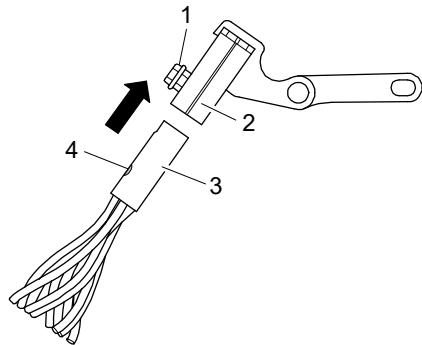

1. Release the brush holding screw (1) at the top of the brush holder (2).
2. Pull the brush (3) out of the brush holder.
3. Push the new brushes all the way into the brush holder. If the brush is inserted correctly, the brush holding screw is positioned exactly over the recess (4) at the brush.

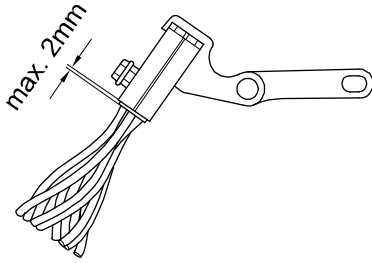

1. Retighten the brush holding screw with a torque of 20-25 Nm.
2. Change the second brush in the same manner.
3. Set the brush height to the highest position.

Original AS brushes

Only use original AS brushes with the spare part number G07325015. Original AS brushes are engraved like this:



Checking the brush strip and the brush holder

⚠ Warning

Improperly maintained or mounted brush strips or holders can pose a high risk of injuries.

- ▶ Work at these parts may only be carried out by an authorised service centre.

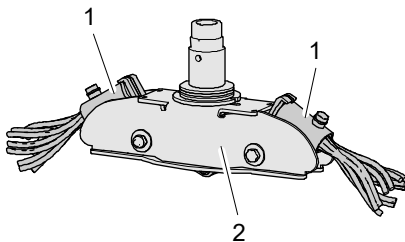

Check the brush strip (2) and brush holder (1) regularly and prior to each use and when you detect noticeable changes regarding cracks and damages. If there are damages, immediately contact your service centre.

The brush holders must be moved easily (remove dirt).

Maintaining the engine

⚠ Warning

If the speed of rotation is set too high, objects can be ejected. The engine can be damaged and noise pollution increases.

- ▶ Do not change the basic setting of the carburetor or the speed control.

The engine manufacturer has prepared the operating manual of the engine. The manual contains all maintenance requirements and warranty conditions for the engine. If warranty work at the engine is required, contact your authorised service centre or the next authorised dealer for engines.

To ensure a long service life of the engine, sufficient engine cooling is required.

Keep the

- engine cover (ventilation grid),
 - silencer (protective grid) and
 - cooling fins of the engine
- clean at all times.

Checking the engine oil level

Never allow the oil level to be too low otherwise the engine can be damaged. Never fill in too much oil. Otherwise, there is the risk that the oil enters and destroys the air filter.

For this, observe the attached operating instructions of the engine.

Checking the spark plugs

Danger

The ignition system generates an electromagnetic field.

- ▶ Wearers of pacemakers must not work on live parts.

Soiled spark plugs reduce the engine output. Clean the electrode of the spark plug with a brass wire brush. Check the electrode gap (see operating instructions of the engine manufacturer). Make sure that the insulator around the electrode is not damaged. Never use a damaged spark plug.

Tighten the spark plug using the correct torque (see operating instructions of the engine manufacturer).

Maintaining the air filter

Warning

Cleaning agents pose a fire and explosion hazard.

- ▶ Never clean the air filter with flammable solvents.

Make sure that the air filter is always clean. A dirty air filter reduces the engine power and leads to increased engine wear and fuel consumption. Independent of the operating hours, change the filter insert at least once a year. Do not operate the engine without air filter.

The foam rubber prefilter picks up the coarse dust. It is possible, in case of strong dust formation, that it has to be cleaned or changed already again after 10 minutes. We recommend to carry along some cleaned or new prefilter in reserve and to replace them at short intervals.

For this, observe the attached operating instructions of the engine.

Checking the drive

1. Put the device on a non-slip surface (e.g. concrete or asphalt).
2. Switch off the engine.
3. Set the gear shift lever to a forward gear.
4. Actuate the drive lever.
5. Try to pull the device backwards.

If the rear wheels lock, the drive is correctly adjusted. If you can pull the device, the drive must be re-adjusted.

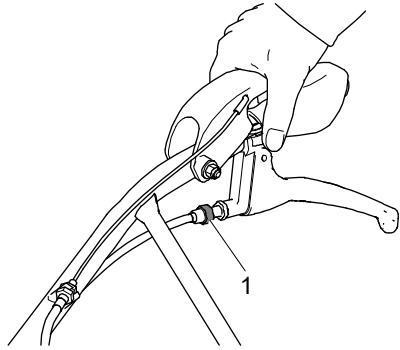

Re-adjusting the drive

Turn the adjusting screw (1) at the drive so that the wheels lock, while the drive is actuated, when the device is pulled. If there is no improvement after the adjustment, have the device checked by an authorised service centre.

Assembly

Scope of delivery

The device is shipped in a carton.

The scope of delivery includes:

- The device.
- Dirt collecting bag.
- This operating manual.
- Manufacturer's certificate.
- Tool bag.
- A set of spare brushes.
- Operator's manual of the engine manufacturer.

Unpacking

1. Remove the loose parts (dirt collecting bag, box inserts) from the box.
2. Cut open the front side of the box.
3. Push the device out of the box.

Guide bar and handlebar

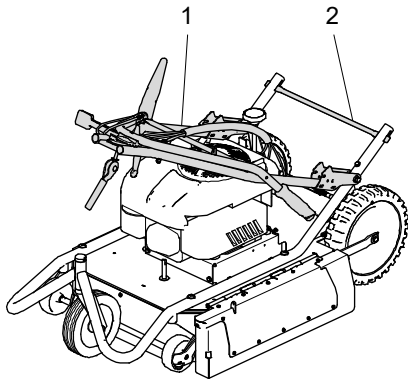

1. Flip the guide bar (1) backwards and engage it with the bar fixing (2).

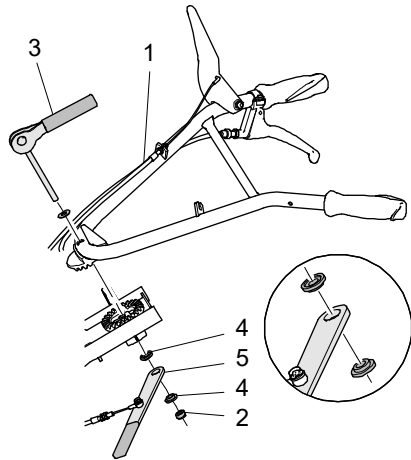

Attention: Do not crush the Bowden cables (1) when fixing the handlebar.

1. Slacken the hexagonal nut (2) at the eccentric lever (3) and remove the hexagonal nut and the two lever bearings (4).
2. Apply the handlebar to the bar.
3. Push on a lever bearing, the slide flap lever (5) and the second lever bearing. Make sure that the collars of both lever bearings point to the side flap lever.
4. Turn the hexagonal nut (2) until the eccentric lever can be tensioned with regular force and is positioned parallel to the bar.
5. Clamp the handlebar with the eccentric tension lever

Dirt collecting bag

Assembling the dirt collecting bag

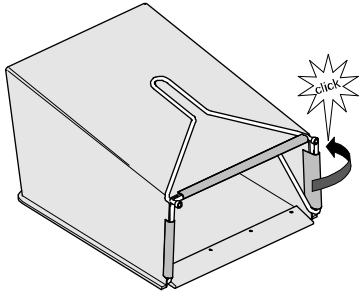
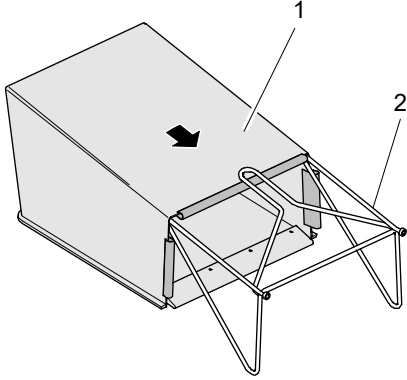

1. Pull the dirt collecting bag (1) over the frame (2).
2. Fasten the dirt collecting bag with plastic profiles to the frame.

Attaching the dirt collecting bag

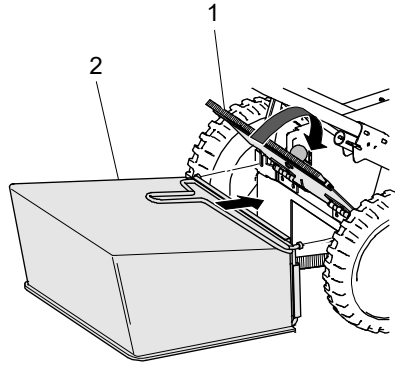

1. Switch off the brushes and wait until the brushes come to a standstill.
2. Lift up the rear flap (1).
3. Insert the dirt collecting bag (2) into the recesses.
4. Lower the rear flap onto the dirt collecting bag.

Storage

Storing the device

Keep the device in a closed, dry, and well ventilated room and out of reach of children. Always eliminate all problems of the device before you store it so that the device is always in a safe-to-operate state. Let the engine cool down before you store the device in closed rooms.

Also observe the notices on storage in the attached operating instructions by the engine manufacturer.

Longer storage

1. Observe the safety instructions for handling the fuel.
2. Emptying fuel tank. Place a piece of hose onto the fuel valve and let the fuel run into an approved fuel container.
3. Emptying carburetor: Start the engine and let it run until it stops by itself.
4. Thoroughly clean the device.
5. Touch up any possible damage to the paint finish (for paint, see Accessories).

Before longer storage, e.g. in the fall, have an authorised service centre check the device!

Also observe the notices on storage in the attached operating instructions by the engine manufacturer.

Restarting

If you want to start the device after a longer storage, carry out the tasks described in chapter Maintenance.

Spare parts

The reliable and safe operation of the device also depends on the quality of the spare parts used. Only use original spare parts and accessories that were approved by "AS-Motor Germany". When foreign parts are installed, the warranty and guarantee shall be void for the foreign part and for the device and for any resulting damage.

Inform your authorised service centre about the device type and serial number of your devices when you order spare parts.

Wear parts

Some parts are wear parts. They wear during use and must be replaced. The warranty does not cover the following parts:

Brush, brush strip, sliding disc, disc spring, cables, V-belt, starter rope, grinding protection, protection skirt, dirt collecting bag, wheels.

Disposal

Depending on the natural cover and soiling of the areas to be cleaned, consider the regulations for disposal of litter. For this, contact your local local/municipal administration.

Dispose of waste oil and fuel in accordance with the local regulations or return it to an oil shop.

Packaging, device, and accessories are made of recyclable materials and must be disposed of accordingly.

Warranty

Please see our AS-Motor website for warranty information.

Please print out the documents that you receive during the online registration. Keep them together with your sales receipt.

Troubleshooting

The following table contains the most frequent problems and their elimination. If more problems occur, contact the closest authorised service centre.

You can find an authorised service centre on our home page www.as-motor.de.

Problem	Possible cause	Remedy
Engine does not start	Engine brake bar is not pressed.	Press the engine brake bar towards the handlebar.
	Fuel valve is closed.	Open fuel valve.
	No fuel is in the tank.	Refill fuel.
	Device was tilted – oil leaked into the air filter.	Replace air filter, unscrew spark plugs and start several times when the fuel valve is closed, dry the spark plugs and screw them back in.
	Engine was flooded due to too many start attempts.	Unscrew spark plugs and start several times when the fuel valve is closed, dry the spark plugs and screw them back in.
	Spark plug connector is pulled off.	Observe the safety instructions! Put spark plug connector back on.
	Air filter is dirty.	Maintain air filter (see chapter Maintenance).
	Spark plugs are dirty, damaged, or incorrect electrode gap.	Clean spark plugs and check electrode gap (see chapter Maintenance). Replace spark plugs if necessary.
	Poor quality, dirty, or old fuel.	Clean fuel system (authorised service centre). Always use fresh fuel.
Engine starts badly or runs irregularly	Air filter is dirty.	Maintain air filter (see chapter Maintenance).
	Poor quality, dirty, or old fuel.	Always use fresh fuel.
	Spark plug is dirty, damaged, or incorrect electrode gap.	Clean spark plug and check electrode gap (see chapter Maintenance). Replace spark plug if necessary.
No drive when drive lever is actuated	Variomatic Bowden cable is insufficiently tensioned.	Authorised service centre
	Drive belt is insufficiently tensioned.	Authorised service centre
Brushes do not turn	Replace friction discs.	Authorised service centre.
	Brush strip is loose.	Authorised service centre.

Strong vibrations during operation	Unbalance at the brushes due to uneven wear or incorrect insertion of the brushes.	Immediately replace the brushes or mount correctly (see chapter Maintenance).
	Brush drive shaft is bent due to collisions with foreign objects.	Authorised service centre.
	Engine fastening is loose.	Authorised service centre.
	Brush strip fastening is loose.	Authorised service centre.
Irregular noises	Loose fastening elements.	Authorised service centre.
	Silencer is defective.	Authorised service centre.
Engine is smoking	Air filter is dirty or drenched with oil.	Maintain or replace air filter (see chapter Maintenance).
	Oil level is too high.	Have authorised service centre lower the oil level to the marking.
Engine gets hot	Ventilation grid is dirty.	Clean ventilation grid.
	Oil level in the engine is too low.	Refill engine oil (see operating instructions of the engine manufacturer).
	Cooling fins of the engine are dirty.	Have cooling fins cleaned by authorised service centre.
Discharge channel is jammed	Engine speed is too low despite full power.	Authorised service centre.
The engine does not switch off	Switching off system is defective.	Close the fuel valve. Authorised service centre.

Technical data

Type	AS 50
Range of application (temperature)	0 - 30 °C For temperatures below 5 °C, observe the engine manufacturer's information regarding the engine oil.
Engine, type Manufacturer Type Cylinder capacity Performance Engine speed	One cylinder four stroke engine Briggs & Stratton Series 850, I/C 190 cm ³ 3,2 kW (4,3 PS) 2800 min ⁻¹
Cutting device, type Working width Brush height	Brushes 50 cm adjustable
Starting device	Rope start
Traction drive	Rear wheel drive with Variomat for variable adjustment of the speed 1,6 -2,5 km/h
Maximum area coverage	up to approx. 1000 m ² /h
Measures and weight Transport size with packaging L/W/H max. tyre dimensions L/W/H Weight	112/65/65 cm 192/61/99 cm 68 kg
Capacities Fuel tank Engine oil Dirt collecting bag	1,2 Liter approx. 0.65 litres SAE 30 or 10W-30 (see Checking the oil level) approx. 25 litres
Sound level according to DIN EN ISO 5395 Measured sound level L _{WA} Sound level at working place L _{pA} Measurement uncertainty k	92,9 dB 80,2 dB 2,5 dB (A)
Vibration emission value according to DIN EN ISO 5395 Hand-arm-vibrations a _{h,w} Measurement uncertainty U	3,3 m/s ² 2,0 m/s ²

Accessories

Operating hours counter:

G06927008

Spray paint 400 ml, colour orange:

G00011050

Declaration of conformity

We declare that the weed remover type AS 50
with serial number starting from 032919010001
as brought into circulation by us conforms to all relevant safety and health requirements of the EC directives listed.

Function:

The device is exclusively intended for cleaning paved areas and edges where moss and weeds are growing.

Applied standards: DIN EN ISO 5395 (in parts)

Place where all technical records are filed:

AS-Motor Germany GmbH & Co. KG
Ellwanger Straße 15
D-74424 Bühlertann

Bühlertann, in January 2019



Eberhard Lange
Managing director



By proxy Frank Einsiedler
Head of development



THE HIGH GRASS MOWER AND 2 STROKE ENGINE MANUFACTURE

AS-Motor is your premium manufacturer for lawn and high grass mowers as well as 2 stroke engines. We offer our customers professional technology for steep slopes, rough terrain, and lawn care. Our extensive product range which includes hand-held entry-level devices up to the world's first all-wheel ride-on mower with remote control will always offer private customers, municipalities service providers the right product. For more than 60 years, we have been developing and producing with a high production depth in Southern Germany and supply our dealer network in more than 30 countries all over the world.

Mulching mower	Mulching mower – the time-saving alternative! AS-Motor mulching mowers shred the grass to create such a fine mulch, almost an “invisible” fertiliser, that sinks right away back into the lawn. Disposal of the cuttings is not required.
Professional lawn mower	Professional lawn mowers with rear or side discharge for every requirement, even with all-wheel drive, brake and reverse gear.
Brush cutter®	An agile lawn mower for maintenance of extensive grassed areas. The Allmäher® reliably mows and mulches metre-high grass, brushes and weeds.
Flail mower	High grass with undergrowth, steep slope or extensive areas in unknown terrain? The movably mounted flail blades of the AS-Motor flail mower give way to rocks and obstacles and chop the cuttings several times over.
Ride-on brush cutter	If extensive areas, weeds and undergrowth up to 1.2 m, the AS-Motor all-wheel mowers are also perfect for steep and even extremely steep terrain. Ease of use and high area performance combined in one compact ride-on mower. For more safety, comfort and efficiency in difficult terrain we have developed the innovative and the world's first remote controlled ride-on mower.
Rotary mower	The cost-effective alternative to the cutter-bar mower. Also ideal for feed production. The grass is not shredded but deposited in straight rows as a windrow next to the machine.
Weed remover	Careful and chemical-free weed removal. The AS-Motor weed removers “WeedHex” mechanically clean paved areas and curb stones from growing weeds – quickly, safely, and efficiently.